11. Schematic Diagrams

	Page
◆ Block Identification of Main PCB	11-2
11-1 S.M.P.S/Power	11-3
11-2 System Control/Servo	11-4
11-3 Audio/Video	11-5
11-4 I/O	11-6
11-5 Function	11-7
11-6 Remote-Control	11-8

Note

For schematic Diagram
 - Resistors are in ohms, 1/8W unless otherwise noted.
 - Circled numbers refer to waveforms.

Special note :

Most semiconductor devices are electrostatically sensitive and therefore require the special handling techniques described under the "electrostatically sensitive (ES) devices" section of this service manual.

Note :

Do not use the part number shown on this drawing for ordering. The correct part number is shown in the parts list (may be slightly different or amended since this drawing was prepared).

Important safety notices :

Components identified with the mark  have the special characteristics for safety. When replacing any of these components. Use only the same type.

◆ **Block Identification of Main PCB**

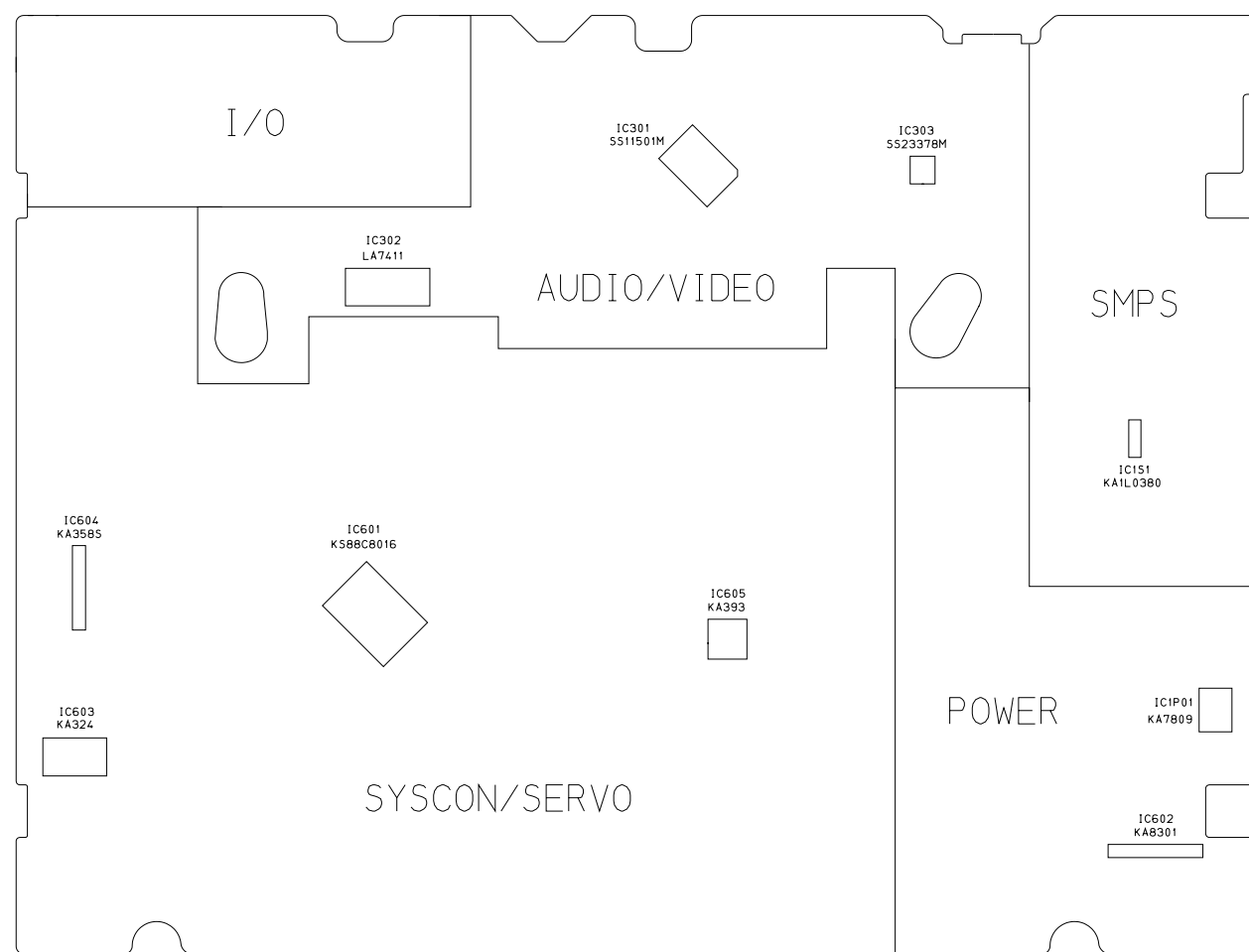

(Component Side)

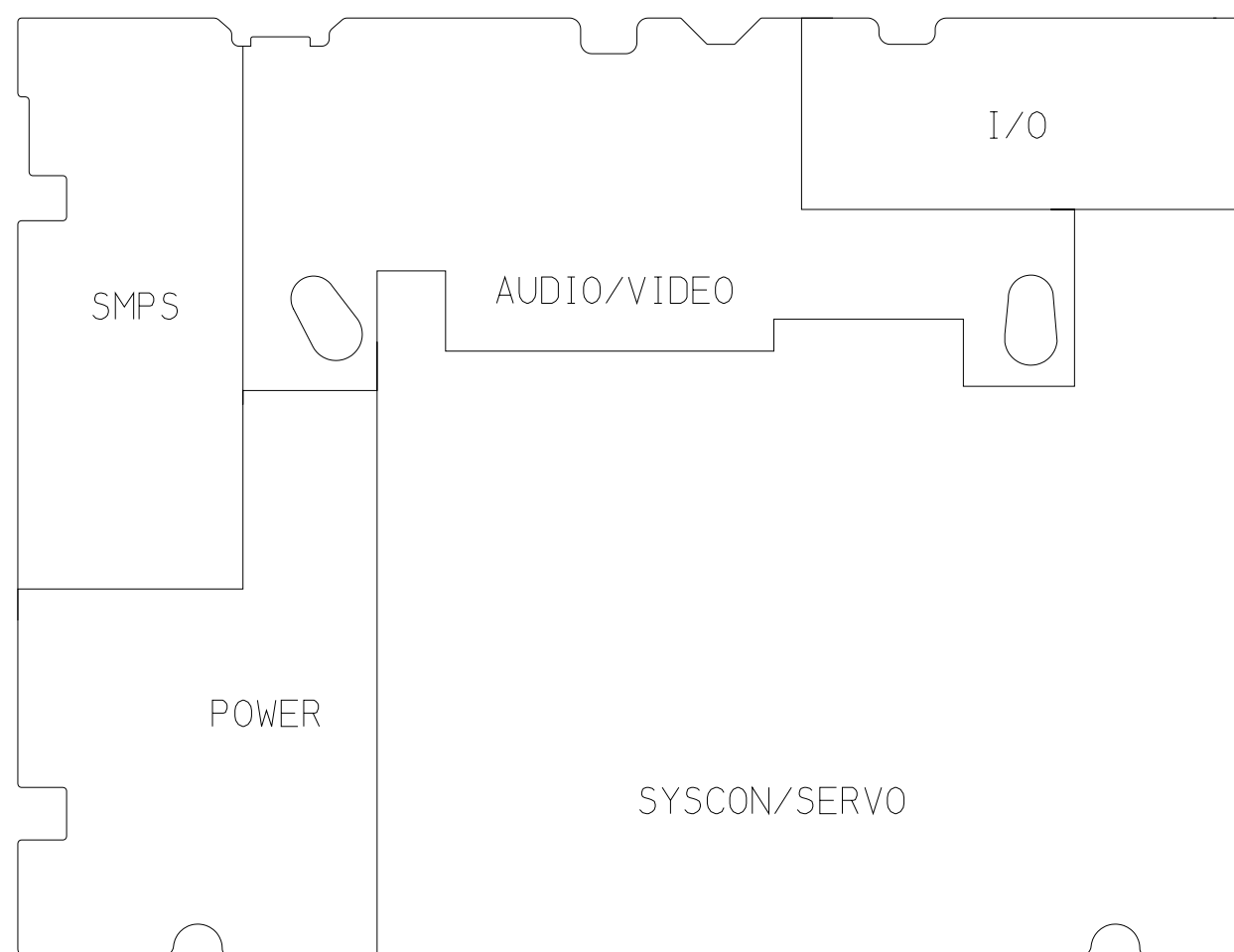

(Conductor Side)

11-1 S.M.P.S/POWER

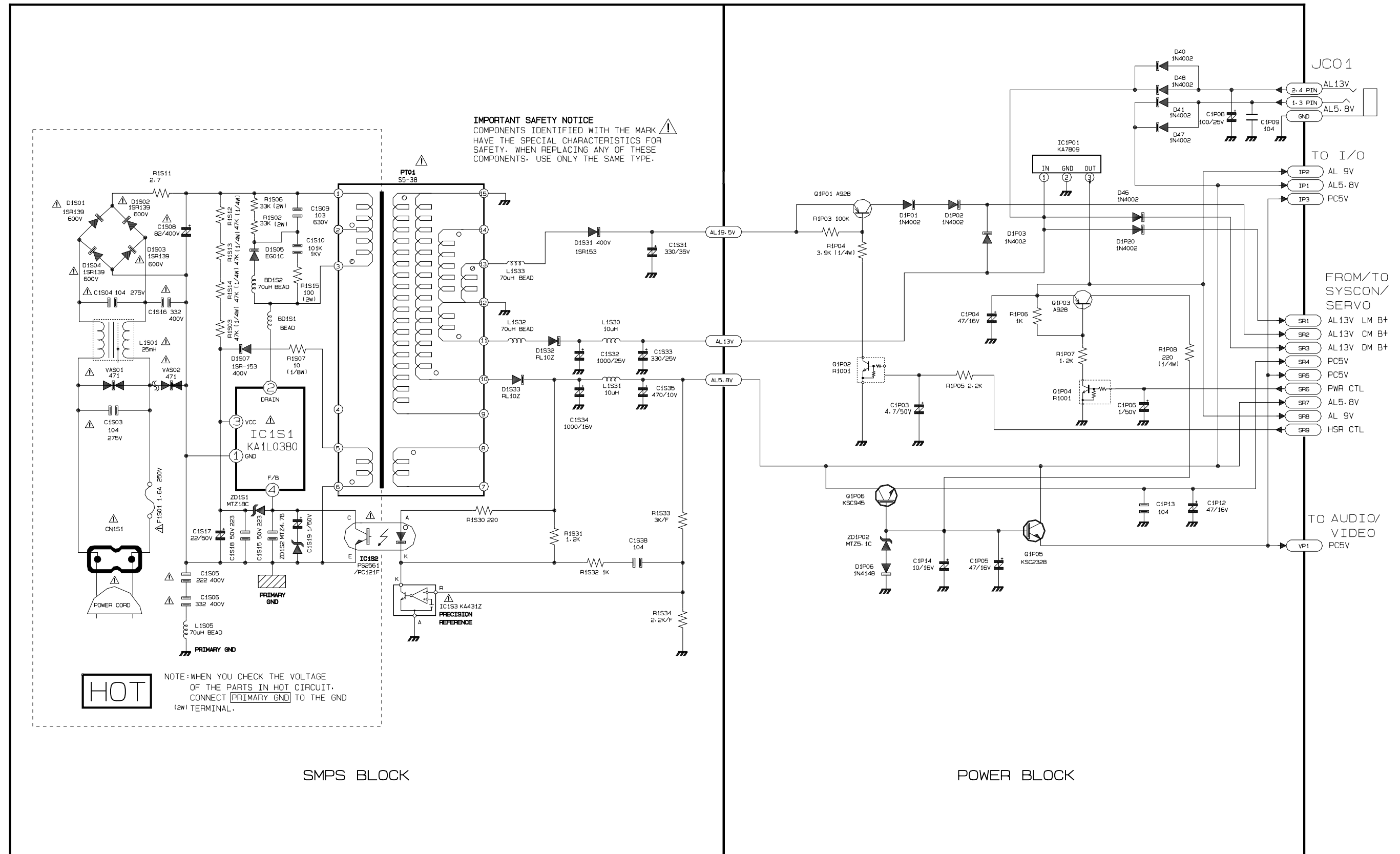

11-2 System Control/Servo

— CYLINDER SPEED CONTROL
 - - - CYLINDER PHASE CONTROL
 — CAPSTAN SPEED CONTROL
 - - - CAPSTAN PHASE CONTROL

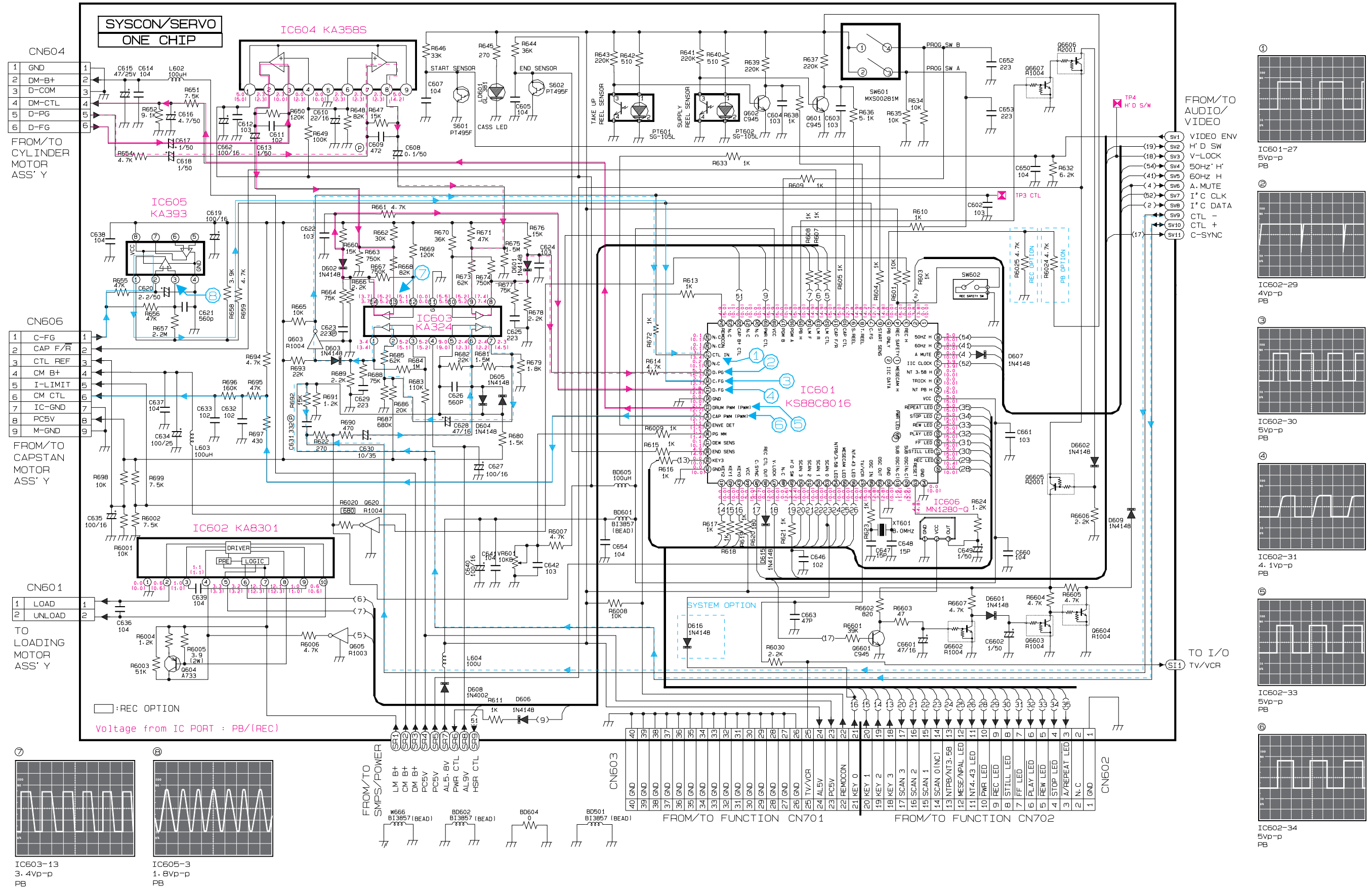

11-3 Audio/Video

— PB Y PROCESS
 - - - PB C PROCESS

— REC Y PROCESS
 - - - REC C PROCESS

— PB AUDIO PROCESS
 - - - REC AUDIO PROCESS

* Voltage level by each port : PB(REC)

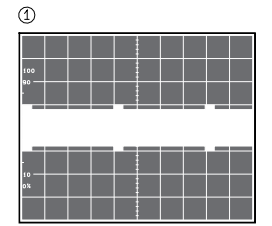
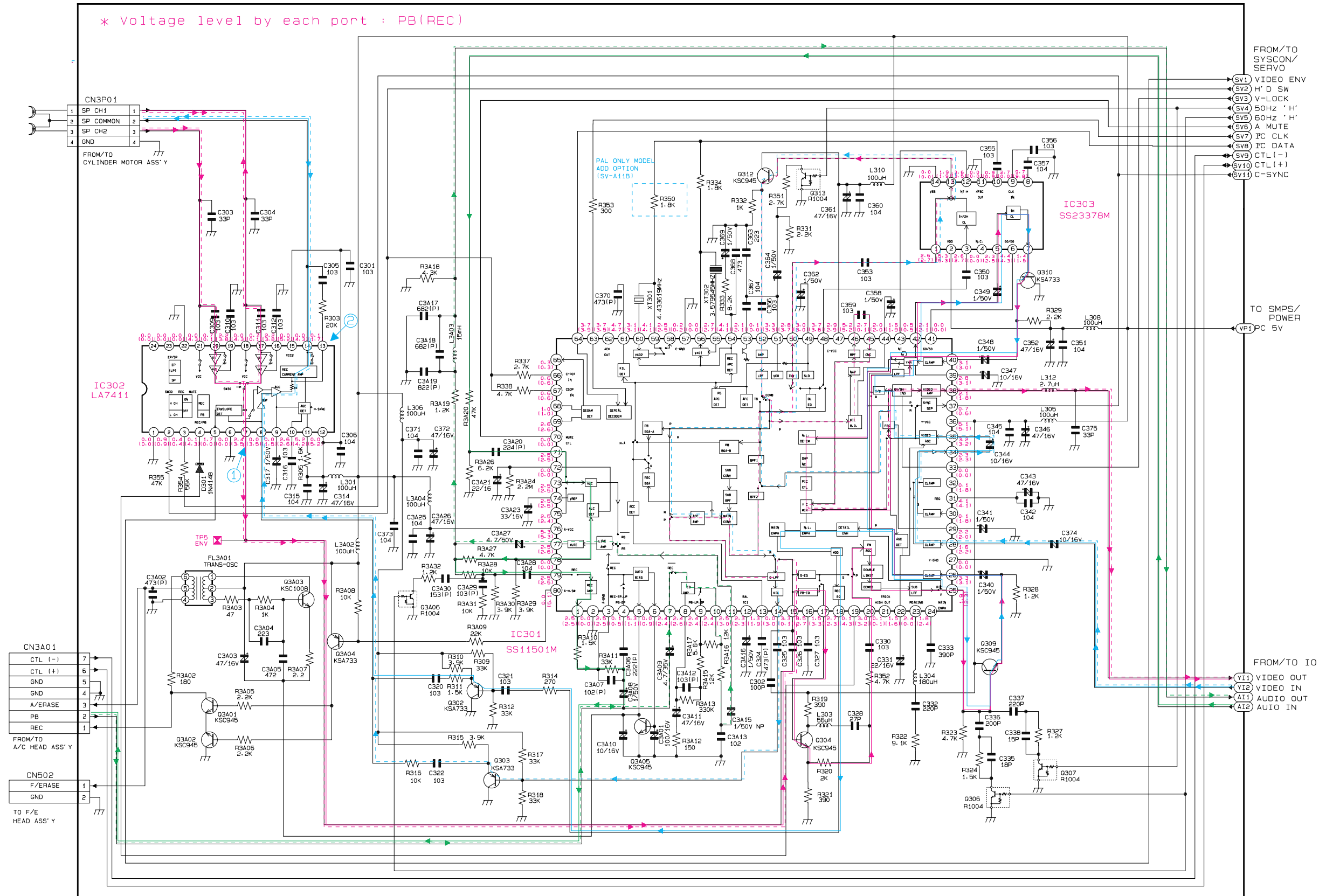

IC302-7
200mVp-p
PLAY

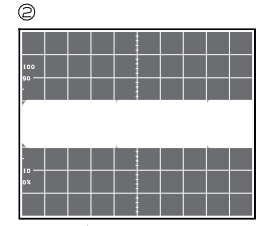

IC302-13
3Vp-p
REC

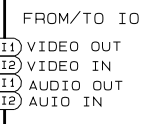
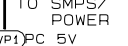
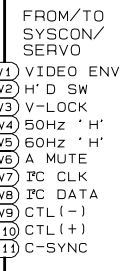
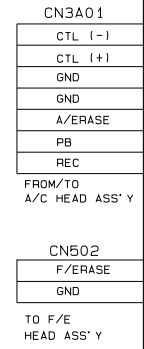

11-4 I/O

— PB VIDEO PROCESS
 - - - PB AUDIO PROCESS

— REC VIDEO PROCESS
 - - - REC AUDIO PROCESS

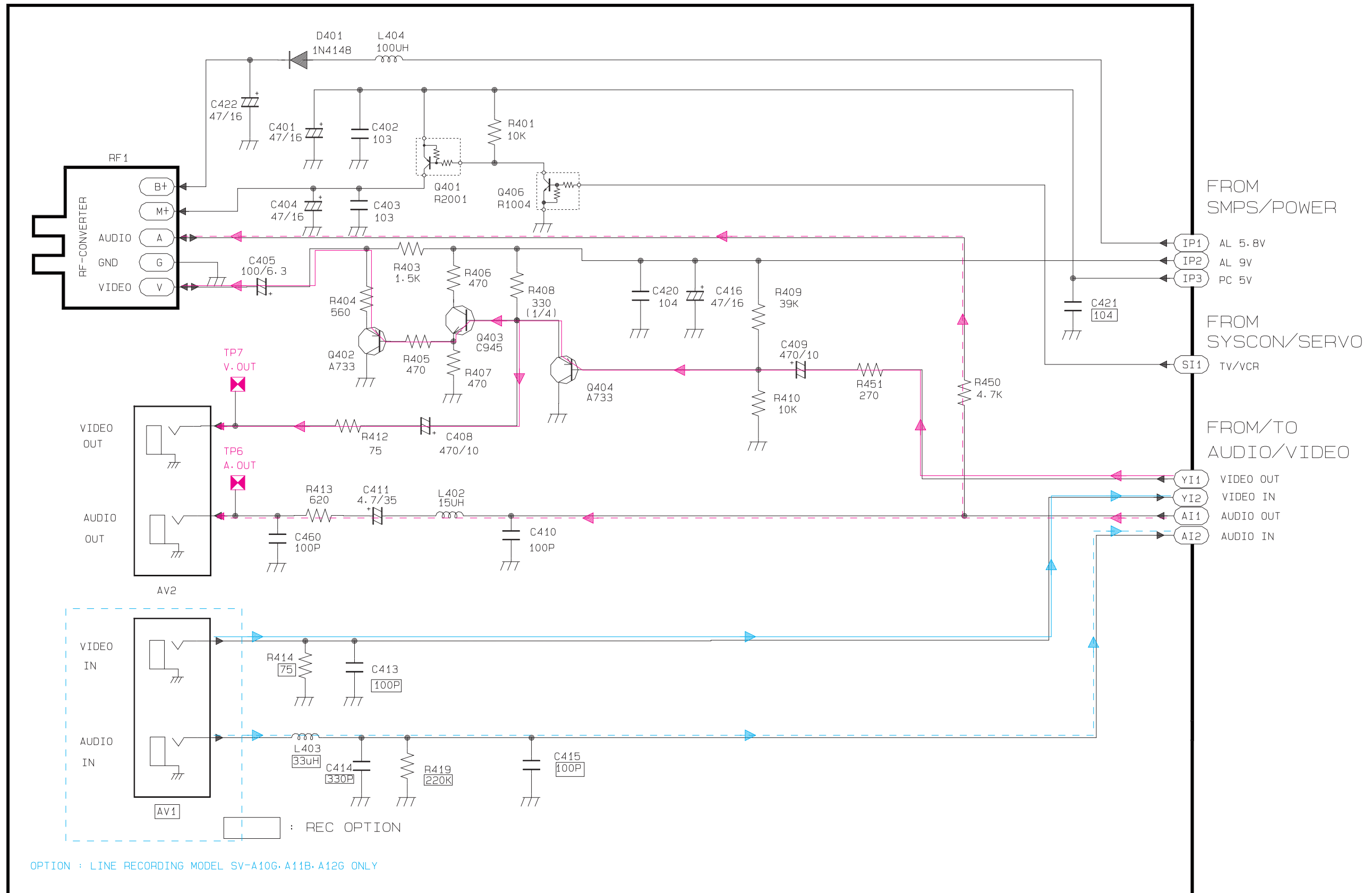

11-5 Function

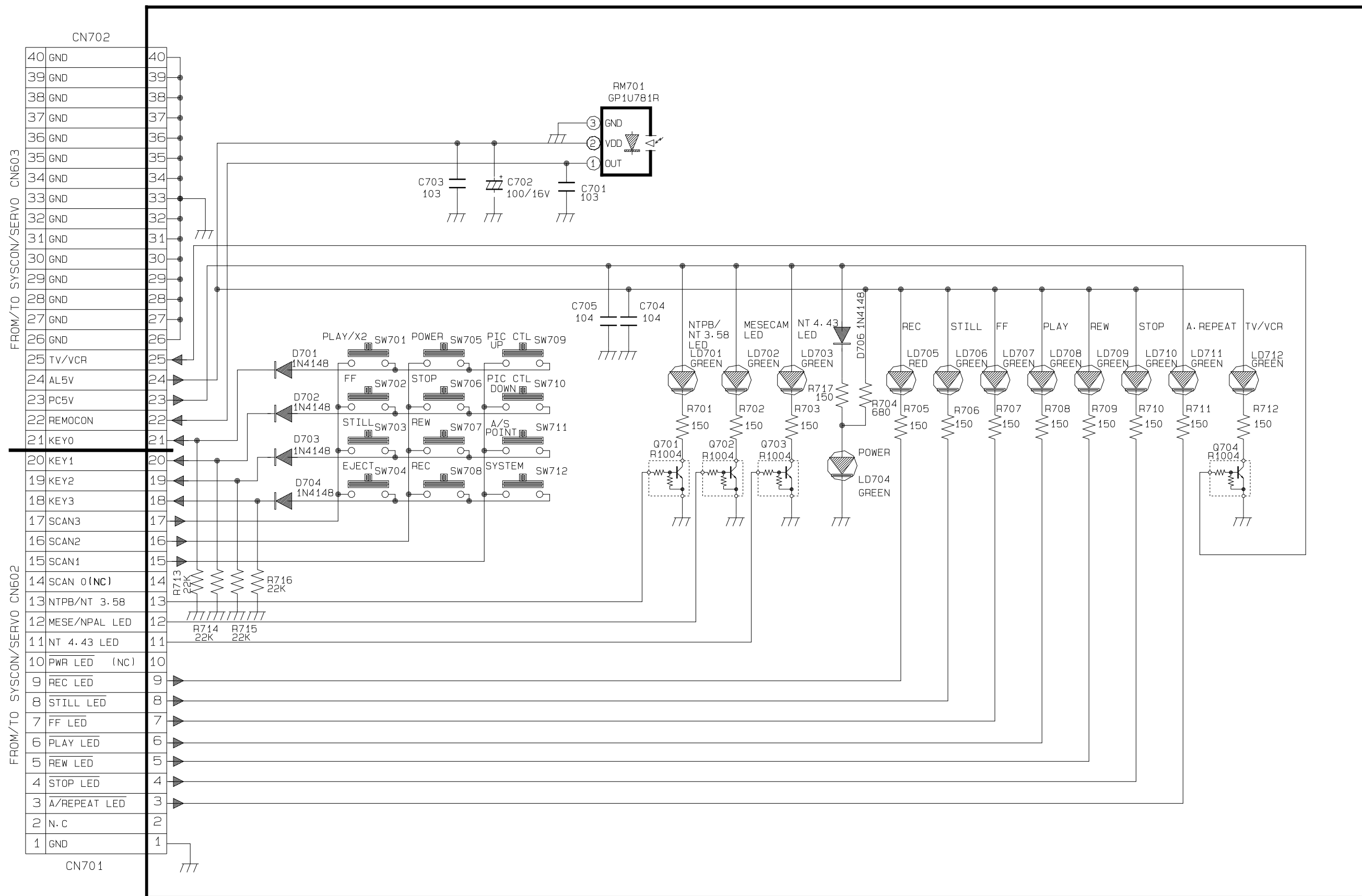

11-6 Remote-Control

